

Compressed Air 0.5MPa 30Nl/min 1/4B

Power 3Phase 200V 3.8kw

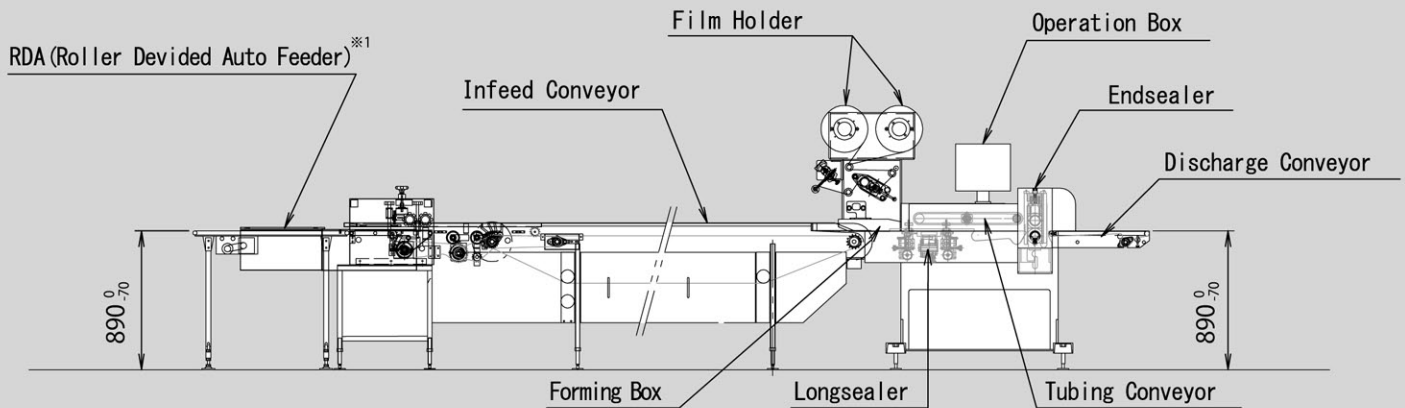

※1 The RDA is an option for NS350 ※Specifications subject to change

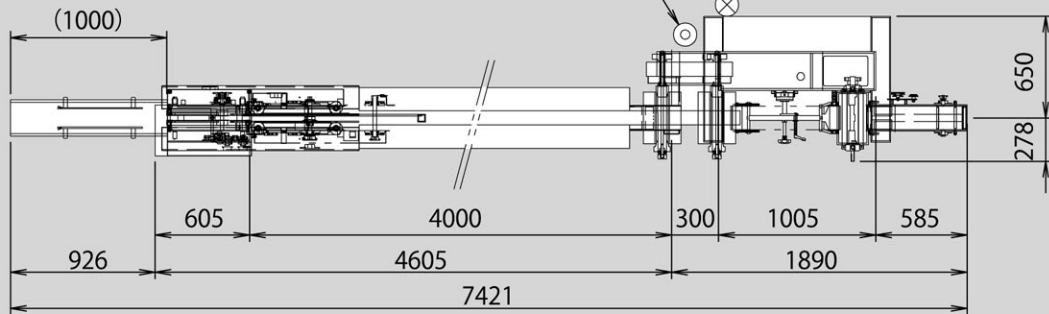

PUSHING ATTACHMENT

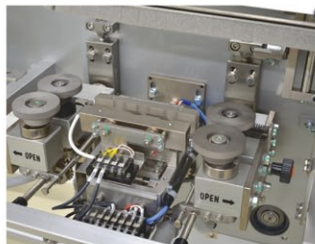

LONGSEALER



OPERATION BOX

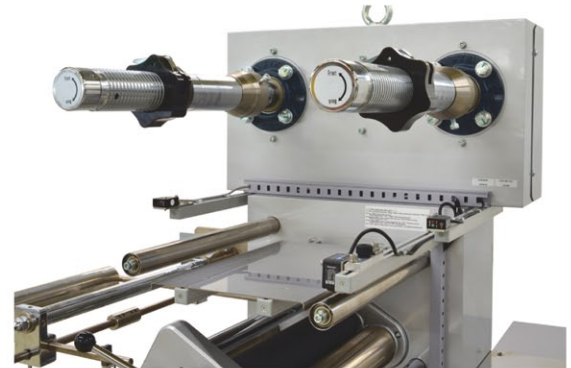

Film Joint Plate (Manual Joint)

【NS350 Feature】

- Specialized model for Instant Dry Noodles
- More simple & compact, but remain heavy duties of N450A
- More accurate registration control system is realized with fine control of servo motor at film driven part.
- Succeeding model of N-450A highly appreciated among users all over the world

【NS350 SPEC】

Product to be wrapped	Instant Dry Noodles
Wrapping speed	Max.160packs/min. (Depends on quality of wrapping material)
Power consumption	3phase,200V,3.8kw
Standard specifications	Touch Panel operation / Heater SSR control type
Maximum film width	350mm
Maximum work size	L126×W126×H34mm

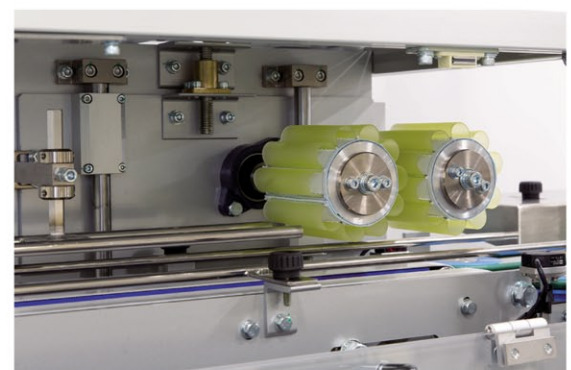

RDA(Roller Devided Auto Feeder)[Option]

Tokiwa Kogyo Co.,Ltd.

<http://www.tokiwrap.co.jp>