

# NEO6-RNS

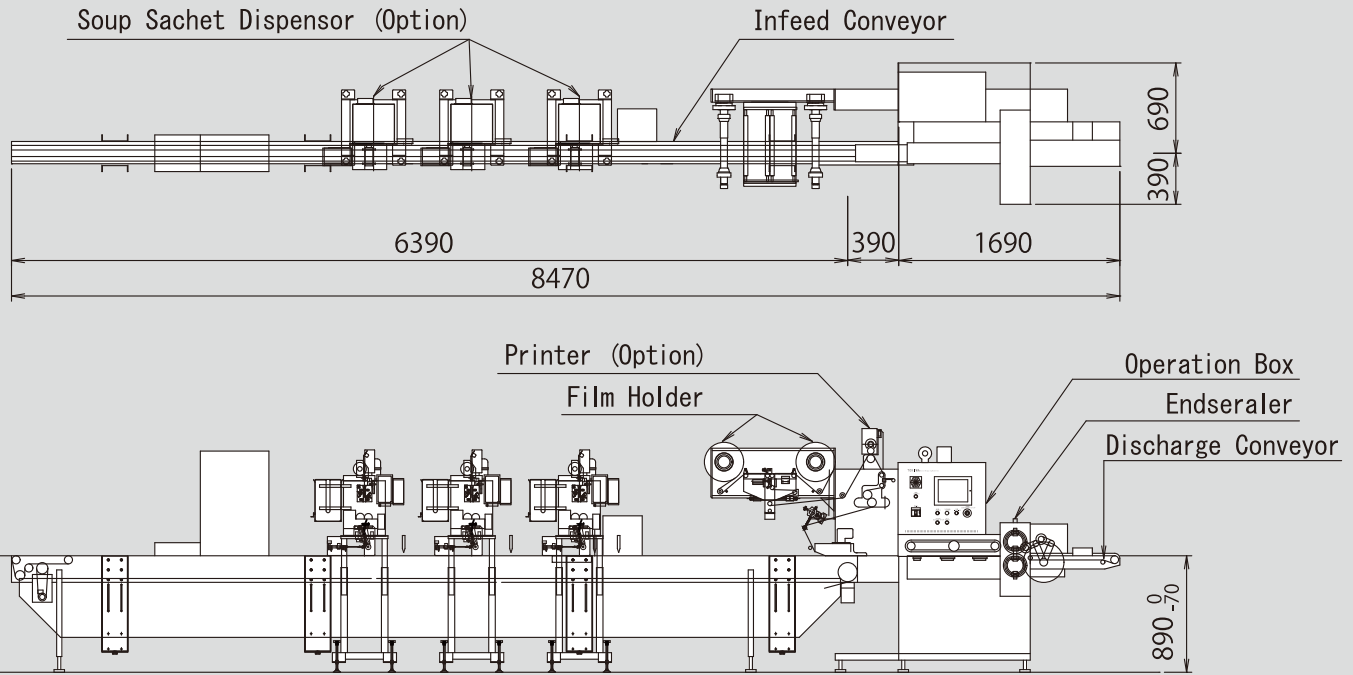

\*Specifications subject to change without notice.

## 【NEO6-RNS Feature】

■The NEO6-RNS Pillow Wrapper realizes high speed wrapping with thicker wrapping film by new Longsealer that runs the wrapping film stably without inside product. Auto wrapping film set up after forming box area.

## 【NEO6-RNS SPEC】

Example product to be wrapped	Instant Dry Bag Noodle and similar.
Wrapping speed	Max. 300packs / min.
Cut pitch	80 ~ 380mm
Power consumption	3phase, 200v, 4.5kw

The Best Machine  
for Bag Noodle



## 【Optional Items】

### ■Belt Divided Autofeeder

Star Wheel Autofeeder, Timing Screw Divider.

### ■Automatic Film Splicer

When detects the end of film activates splice to next film roll. Splice by heat seal. Splice by double faced adhesive tape.

### ■Web Guiding Systems

It minimize web position errors to keep center position of the film to have stable long Seal. Using together with Automatic Film Splicer, ensure higher productivity.

### ■Detection of Jamming at Endsealer

When jamming small piece of product at endsealer, automatically reject the package on discharge conveyor.

### ■No Product Pass

Empty bag is not made when detecting no product on infeed conveyor.

### ■Date Coder

Printer is the device that prints the date and lots code etc., best before eating in case food.

Thermal Transfer Coder : Numeral, graphics, bar code etc is printed with Heat Sensitive Ribbon. The printing letter shape etc. can be changed easily through controller. No manual type change.

Hot Ink Roll Coder : Manual type change is necessary for printing shape change.

#### Head office and main factory

2-190-9 Yamada Nishi-ku  
Sakai-shi Osaka 593-8316  
Japan  
Phone +81-72-273-1234

#### Branch and factory

2-2-18 Shiratori,  
Katsushika-ku, Tokyo  
Phone +81-3-3603-3271

#### Sales Office

Kyushu : Hakata-eki  
Higashiguchi Bldg. 7th floor,  
1-11-15 Hakata-eki Higashi,  
Hakata-ku, Fukuoka-shi  
Phone +81-92-451-1428